

Woodhead Emergency Downlight

Installation and Operating Manual

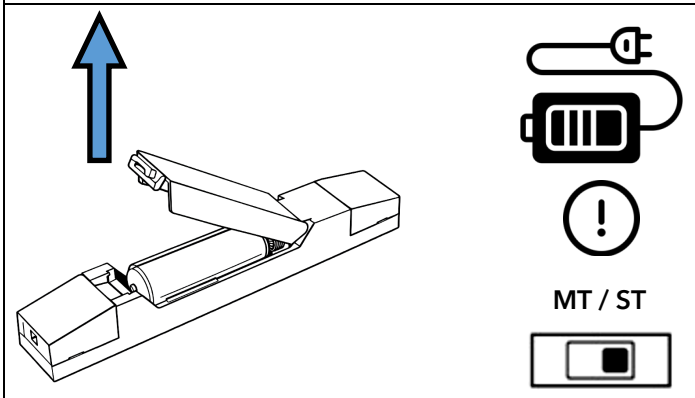

| | EN | DE | FR | ES | IT | NL | SE | PL |
|---|-------|-------|--------|--------|---------|-------|------|-----------|
| L | BROWN | BRAUN | MARRON | MARRON | MARRONE | BRUIN | BRUN | BRAZOWY |
| N | BLUE | BLAU | BLEU | AZUL | BLU | BLAUW | BLĄ | NIEBIESKI |

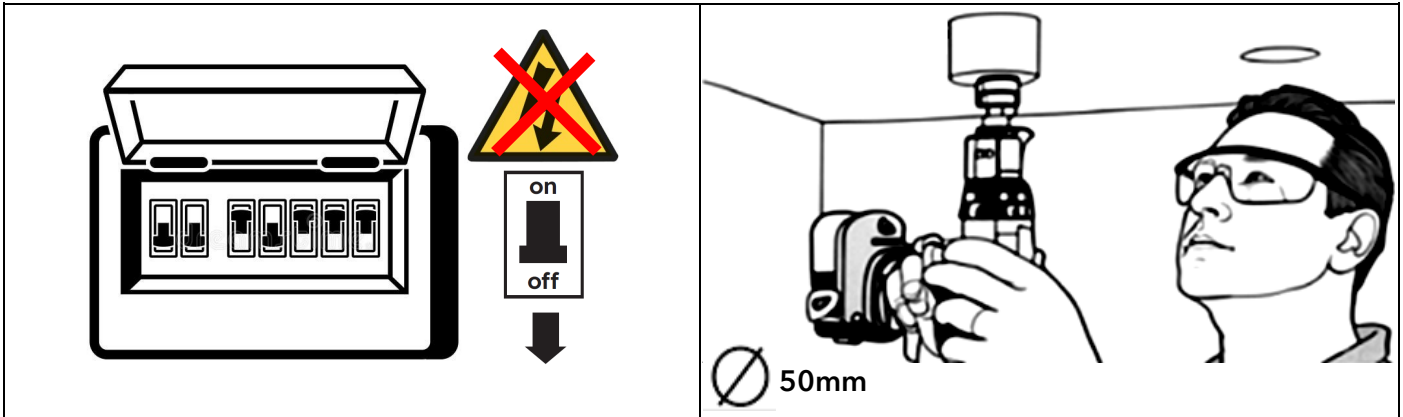
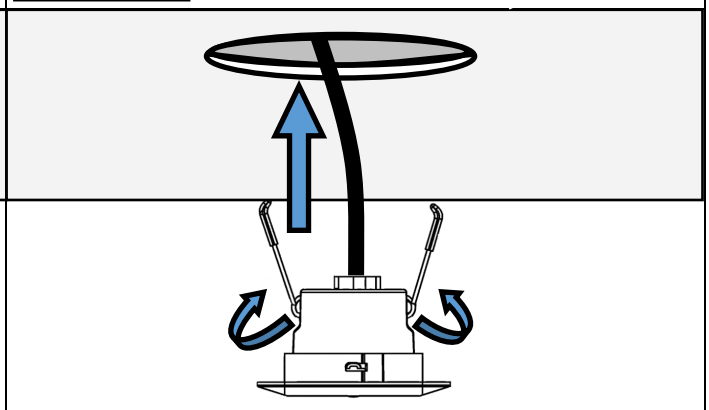
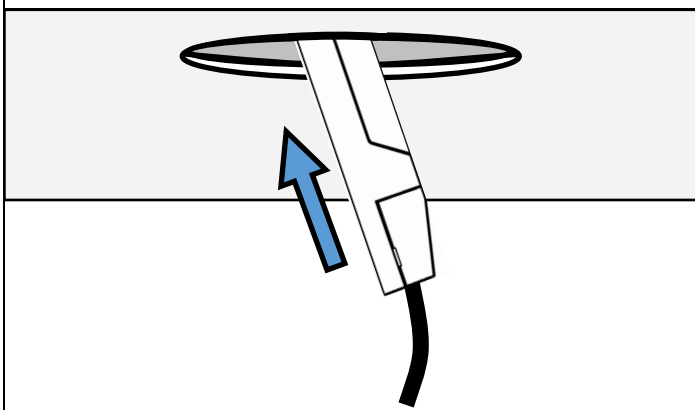

| Colour | LED Indication | Status |
|--------|--|--|
| Green | Permanent | Normal Function - Battery is charged |
| Green | Fast Flashing (0.1 sec on ~ 0.1 sec off) | Monthly Function Test In Progress (Self Test) |
| Green | Slow Flashing (1 sec on ~ 1 sec off) | Annual 3hr Duration Test In Progress (Self Test) |
| Red | Permanent | Load Failure - Check wiring / replace unit |
| Red | Slow Flashing (1 sec on ~ 1 sec off) | Battery Fault - Check connection |

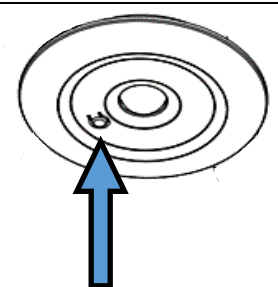

TEST

To reset a unit after failure, press and hold the test button on the front face for 3 seconds while the unit is powered off.

