

GB - This product contains a light source of energy efficiency class <C>.
FR - Ce produit contient une source lumineuse de classe d'efficacité énergétique <C>.
DE - Dieses Produkt enthält eine Lichtquelle der Energieeffizienzklasse <C>.
IT - Questo prodotto contiene una sorgente luminosa di classe di efficienza energetica <C>.
ES - Este producto contiene una fuente luminosa de clase de eficiencia energética <C>.
NL - Dit product bevat een lichtbron met energie-efficiëntieklasse <C>.
SE - Den här produkten innehåller en ljuskälla med energieffektivitetsklassen <C>.
PL - Ten produkt zawiera źródło światła o klasie efektywności energetycznej <C>.

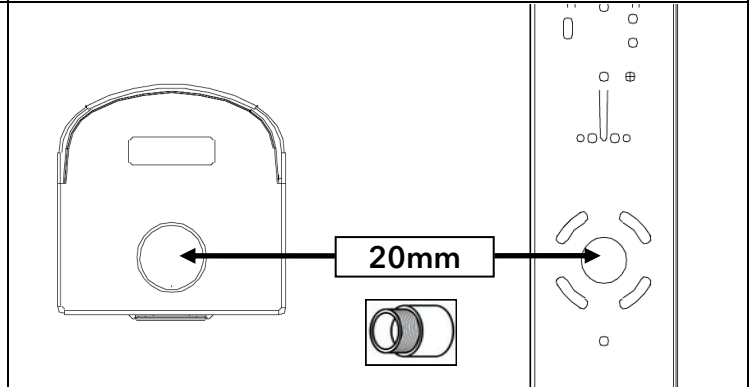
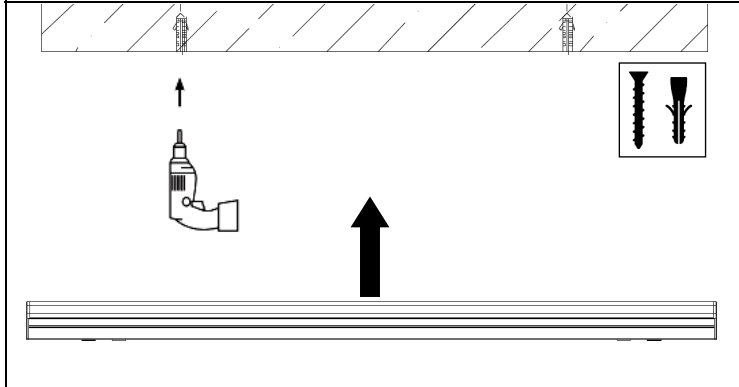
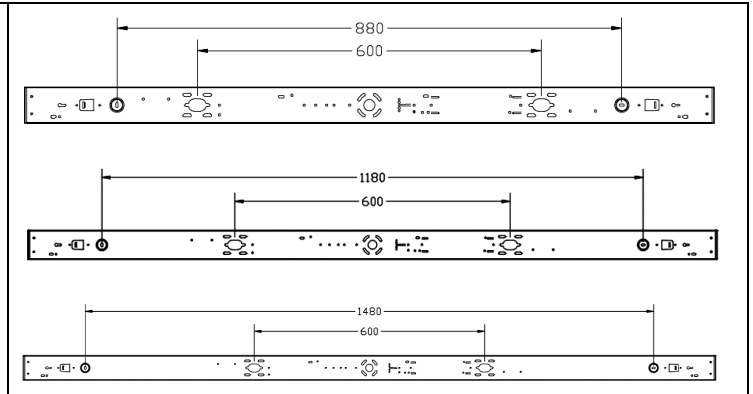
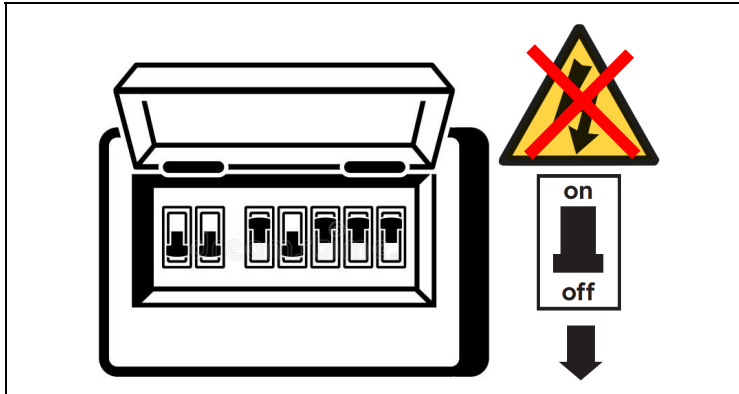

	EN	DE	FR	ES	IT	NL	SE	PL
LS	BROWN	BRAUN	MARRON	MARRON	MARRONE	BRUIN	BRUN	BRAZOWY
E	GREEN-YELLOW	GRUN-GELB	VERT-JAUNE	VERDE-AMARILLO	VERDE-GIALLO	GROEN-GEEL	GRÖN-GUL	ZIELONY-ZÓŁTY
N	BLUE	BLAU	BLEU	AZUL	BLU	BLAUW	BLĄ	NIEBIESKI
L	BLACK	SCHWARZ	NOIR	NEGRA	NEGRO	ZWART	SVART	CZARNY

Watts	Wattage Select
18W	ON
36W	ON

Watts	Wattage Select
28W	ON
56W	ON

Watts	Wattage Select
25W	ON
50W	ON

3000K
4000K
6000K

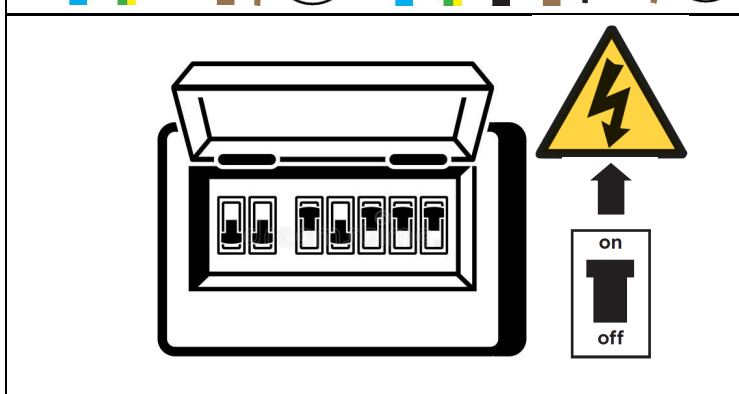
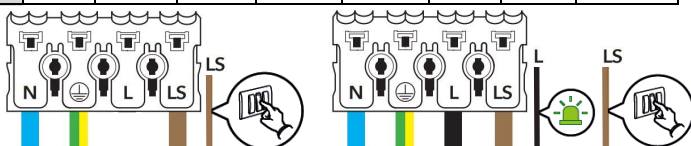

430916 Microwave Sensor settings

Sensor Area		Hold Time			Lux Sensor				
1	2	3	4	5	6	7	8		
ON	ON	ON	ON	ON	5 sec	ON	ON	ON	> 2 lux
-	ON	75%	-	ON	ON	30 sec	ON	ON	>10 lux
ON	-	50%	ON	-	ON	90 sec	-	ON	>30 lux
-	-	25%	-	-	ON	5 min	ON	-	>50 lux
			ON	ON	-	20 min	-	-	OFF
			-	-	-	30 min			

EMERGENCY FUNCTION

Emergency lighting luminaires must be installed and maintained in accordance with the Emergency Lighting Code of Practice : BS 5266-1

Connect a permanent live supply. Do not connect switches or controls. LED status indicator displays normal function and faults. On mains failure emergency mode will operate. Self-Test: 30 day function tests - Annual 3 hour duration test automatically after 24 hour charge and 12 monthly. Do not use manual test switch when self-test selected. **Ensure battery is connected during installation.**

Engineer:				Tel:		
Location/Luminaire ref:						
Test Type	Date	Sign	Pass/ Fail	Date	Sign	Pass/ Fail
1						
2						
3						
4						
5						
6						
7						
8						
9						
10						
11						
12						
ANNUAL						
Test Type	Date	Sign	Pass/ Fail	Date	Sign	Pass/ Fail
1						
2						
3						
4						
5						
6						
7						
8						
9						
10						
11						
12						
ANNUAL						

FR: Les luminaires d'éclairage de secours doivent être installés et entretenus conformément à la norme NF C 71-800. Raccorder une alimentation permanente. Ne pas raccorder d'interrupteurs ni de dispositifs de commande. Le voyant LED indique le fonctionnement normal et les défauts. En cas de coupure secteur, le mode secours s'active. Auto-test : test fonctionnel tous les 30 jours, test d'autonomie de 3 heures automatiquement après une charge initiale de 24 heures, puis annuellement. Ne pas utiliser d'interrupteur de test manuel en mode auto-test. **S'assurer que la batterie est connectée lors de l'installation.**

DE: Notleuchten müssen gemäß DIN VDE 0108-100 installiert und gewartet werden. Dauerstromversorgung anschließen. Keine Schalter oder Steuergeräte anschließen. Die LED-Anzeige zeigt Normalbetrieb und Fehler an. Bei Netzausfall wird der Notbetrieb aktiviert. Selbsttest: Funktionstest alle 30 Tage, automatische 3-Stunden-Dauerprüfung nach 24 Stunden Erstladung und anschließend jährlich. Keinen manuellen Testschalter im Selbsttestmodus verwenden. **Sicherstellen, dass die Batterie während der Installation angeschlossen ist.**

IT: Gli apparecchi di illuminazione di emergenza devono essere installati e mantenuti in conformità alla norma CEI EN 50172. Collegare un'alimentazione permanente. Non collegare interruttori o dispositivi di controllo. L'indicatore LED mostra il funzionamento normale e i guasti. In caso di interruzione della rete, si attiva la modalità di emergenza. Auto-test: test funzionale ogni 30 giorni, test di autonomia di 3 ore automaticamente dopo 24 ore di ricarica iniziale, quindi annualmente. Non utilizzare un interruttore di test manuale in modalità auto-test. **Assicurarsi che la batteria sia collegata durante l'installazione.**

ES: Las luminarias de emergencia deben instalarse y mantenerse conforme a la norma UNE-EN 50172. Conectar una alimentación permanente. No conectar interruptores ni dispositivos de control. El indicador LED muestra el funcionamiento normal y los fallos. En caso de fallo de red, se activa el modo de emergencia. Auto-test: prueba funcional cada 30 días, prueba de autonomía de 3 horas automáticamente tras 24 horas de carga inicial y posteriormente de forma anual. No utilizar un interruptor de prueba manual en modo auto-test. **Asegúrese de que la batería esté conectada durante la instalación.**

NL: Noodverlichtingsarmaturen moeten worden geïnstalleerd en onderhouden volgens NEN-EN 50172. Sluit een permanente voeding aan. Sluit geen schakelaars of regelapparatuur aan. De LED-indicator geeft normaal functioneren en storingen weer. Bij netuitval wordt de noodmodus geactiveerd. Zelftest: functietest elke 30 dagen, automatische 3-uurs duurttest na 24 uur eerste lading en vervolgens jaarlijks. Gebruik geen handmatige testschakelaar in zelftestmodus. **Zorg ervoor dat de batterij is aangesloten tijdens de installatie.**

SE: Nödbelysningsarmaturer ska installeras och underhållas i enlighet med SS-EN 50172. Anslut permanent spänningsmatning. Anslut inga brytare eller styrningar. LED-indikatorn visar normal drift och fel. Vid strömavbrott aktiveras nödläge. Självtest: funktionstest var 30:e dag, automatisk 3-timmars drifttest efter 24 timmars initial laddning och därefter årligen. Använd inte manuell testbrytare i självtestläge. **Säkerställ att batteriet är anslutet vid installation.**

PL: Oprawy oświetlenia awaryjnego muszą być instalowane i konserwowane zgodnie z normą PN-EN 50172. Podłączyć stałe zasilanie. Nie podłączać przełączników ani urządzeń sterujących. Wskaźnik LED sygnalizuje normalną pracę i usterki. W przypadku zaniku zasilania uruchamia się tryb awaryjny. Auto-test: test funkcjonalny co 30 dni, automatyczny test 3-godzinny po 24 godzinach ładowania początkowego, a następnie co roku. Nie używać ręcznego przełącznika testowego w trybie auto-test. **Upewnić się, że bateria jest podłączona podczas instalacji.**

<p>EN: Install by a qualified person in accordance with national regulations. Isolate supply before installation.</p> <p>FR: Installer par une personne qualifiée conformément aux réglementations nationales. Isoler l'alimentation avant installation.</p> <p>DE: Installation durch qualifiziertes Personal gemäß nationalen Vorschriften. Versorgung vor Installation trennen.</p> <p>IT: Installazione da parte di personale qualificato secondo le normative nazionali. Scollegare l'alimentazione prima dell'installazione.</p> <p>ES: Instalación por personal cualificado conforme a la normativa nacional. Desconectar la alimentación antes de la instalación.</p> <p>NL: Installatie door een gekwalificeerd persoon volgens nationale regelgeving. Voeding loskoppelen vóór installatie.</p> <p>SE: Installation ska utföras av behörig person enligt nationella regler. Koppla från strömmen före installation.</p> <p>PL: Instalacja przez wykwalifikowaną osobę zgodnie z przepisami krajowymi. Odłączyć zasilanie przed instalacją.</p>
--

<p>EN: 5-year warranty. For terms and conditions visit our website: www.lumineux.co.uk</p> <p>FR: Garantie de 5 ans. Pour les conditions générales, consultez notre site web: www.lumineux.co.uk</p> <p>DE: 5 Jahre Garantie. Für die Garantiebedingungen besuchen Sie unsere Website: www.lumineux.co.uk</p> <p>IT: Garanzia di 5 anni. Per termini e condizioni visitare il nostro sito web: www.lumineux.co.uk</p> <p>ES: Garantía de 5 años. Para términos y condiciones visite nuestro sitio web: www.lumineux.co.uk</p> <p>NL: 5 jaar garantie. Voor de garantievoorwaarden bezoekt u onze website: www.lumineux.co.uk</p> <p>SE: 5 års garanti. För villkor, besök vår webbplats: www.lumineux.co.uk</p> <p>PL: 5-letnia gwarancja. Warunki gwarancji dostępne na stronie: www.lumineux.co.uk</p>
--

To reset a failure press and hold the reset button on the base of the emergency pack. Hold through 2 flashes, 3 flashes, 4 flashes – keep holding until the indicator and emergency lamp both illuminate, then release the button. The emergency unit has now been reset.

End Of Life Disposal:

This product falls within the scope of the Waste Electrical & Electronic Equipment Directive (WEEE) and must not be disposed of with general or household waste.

At end-of-life, this product should be recycled through appropriate collection facilities. B&T Associates Ltd t/a Lumineux Lighting complies with the requirements of the WEEE Directive and supports responsible disposal and environmental protection. Where applicable, take-back arrangements may be available. Disassembly instructions for recycling are available on request. For further information, please contact us or visit our website.

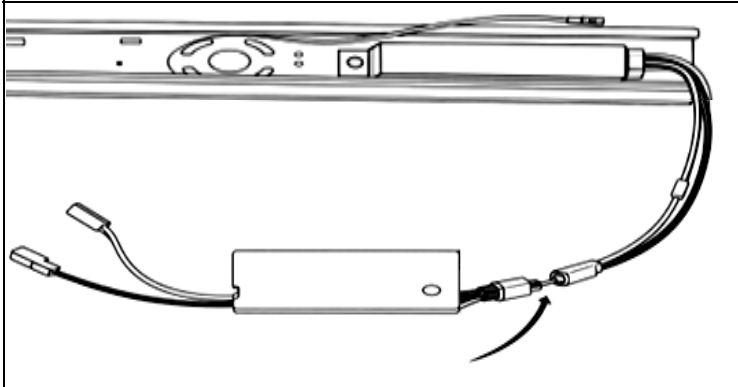
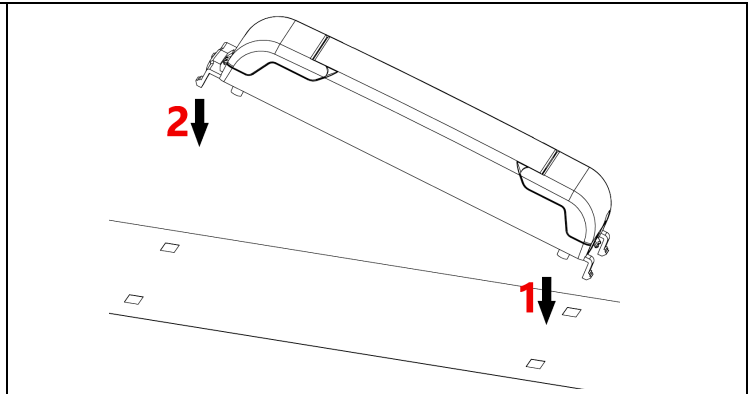
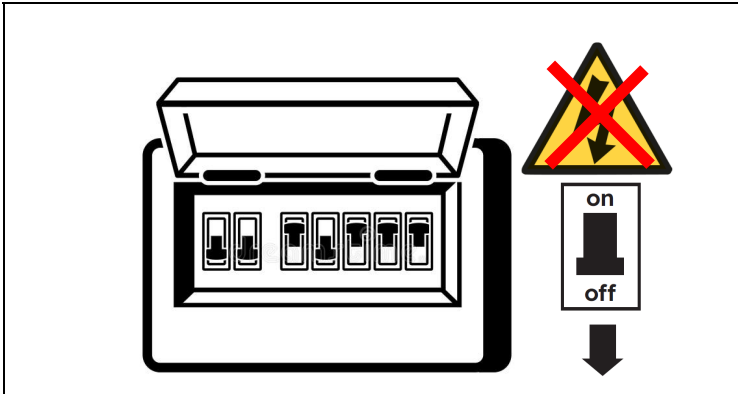

EN	DE	FR	ES	IT	NL	SE	PL
WHITE	WEIß	BLANC	BLANCO	BIANCO	WIT	VIT	BIAŁY
->	->	->	->	->	->	->	->
WHITE	WEIß	BLANC	BLANCO	BIANCO	WIT	VIT	BIAŁY

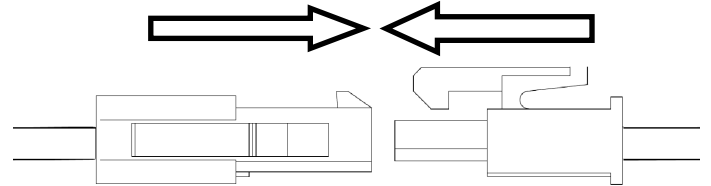

EN	DE	FR	ES	IT	NL	SE	PL
BLACK	SCHWARZ	NOIR	NEGRA	NEGRO	ZWART	SVART	CZARNY
->	->	->	->	->	->	->	->
BLACK	SCHWARZ	NOIR	NEGRA	NEGRO	ZWART	SVART	CZARNY

